

HYPERTUBE L21 EU

TECHNICAL INSTRUCTIONS INSTALLER USER

N° 05000692 / 0

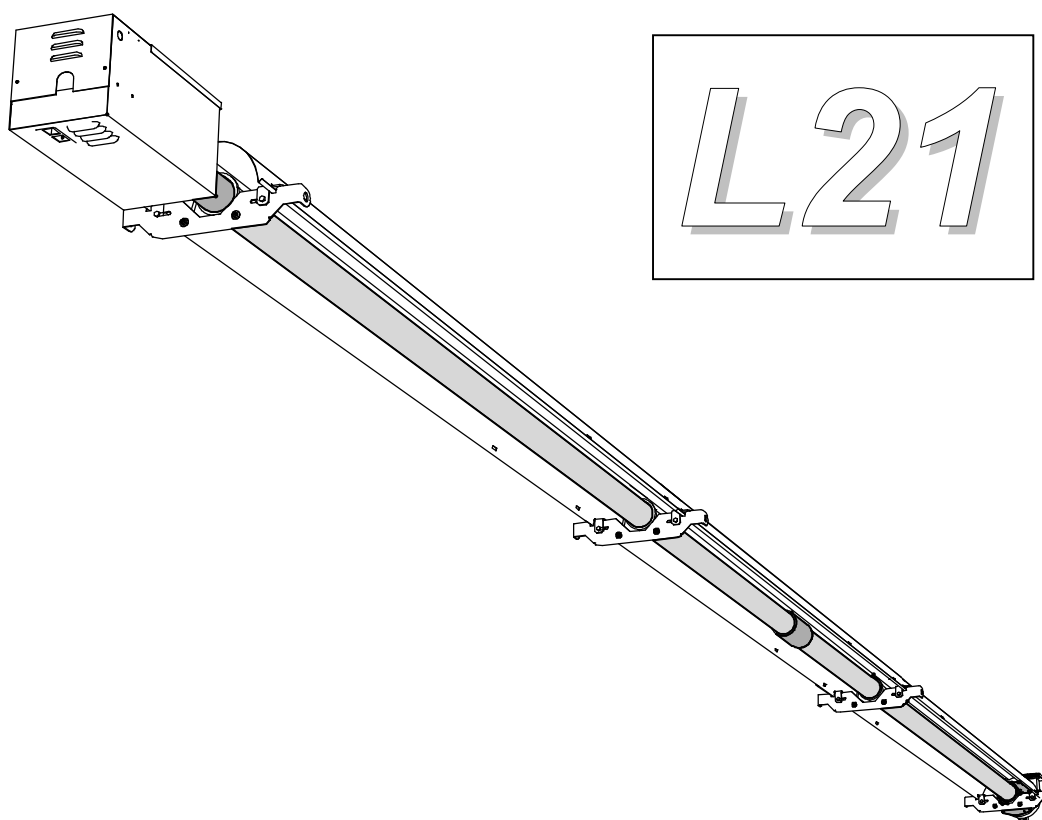

Warning

Please read this document carefully before starting the installation.

The document accompanying each unit is meant for the installer and the user. **Leave it at the end-user after installation.** This document contains instructions for installing the heater and flue system and describes in particular how to carry out gas connection & electrical connection. Subcontractors must also receive this document.

Manufacturer:

SBM
3 cottages de la Norges
21490 CLENAY
FRANCE

CE 1312

INDEX

1	RULES	P 3
2	TECHNICAL SPECIFICATIONS	P 4
3	DIMENSIONS	P 5
4	APPLIANCE ASSEMBLY	P 6
	a/ Packaging	
	b/ Preparation of tubes	
	c/ Appliance assembly	
	d/ Burner, extractor and sleeves assembly	
	e/ Reflectors assembly	
	f/ Mounting of anti-rotation strap	
5	HANGING AND FIXING THE UNIT	P 10
6	SAFETY CLEARANCES	P 12
	a/ Distances to unprotected combustible materials	
	b/ Minimum recommended mounting height	
7	EVACUATION OF COMBUSTION PRODUCTS	P 13
	Type A	
	Type B	
8	INSTALLATION METHOD & CONNECTIONS	P 15
	a/ Electrical connection	
	b/ Flue system	
	c/ Gas connections	
	d/ 'Failure signal transmission' option	
9	TEMPERATURE REGULATION	P 17
10	PROGRAMMING	P 17
11	SETTING UP	P 18
12	MAINTENANCE	P 18
13	GAS CHANGE	P 20
14	FAULTS – POSSIBLE CAUSES - SOLUTIONS	P 21
15	ELECTRICAL DIAGRAM	P 22
16	OPTIONS ON REQUEST	P 23
17	SPARES PARTS	P 23

1 Rules

GENERAL WARNING

- The installation will have to be in compliance with the norms in force and be carried out according to traditional rules by a skilled worker.
- The installer will have to refer to the various existing official documents according to the different stages that the installation will require (see enclosure 1 at the end of this document).
- The radiant tubes are CE certified and approved for use in many countries. In order to meet the national requirements only appropriate models should be used (in case of doubt, please contact us). The guarantee of conformity to regulations and standards does not apply to units designed for the French market but installed in foreign countries.
- The hotpoint of the heater amounts to more than 150°C. Please follow the directives of the competent authorities and respect the rules in force related to classified buildings or risky sites.
- The use is also prohibited in all the premises where there are corrosive fumes, even if there are small quantities of them, whose combination with water vapor and/or combustion products will entail abnormal deteriorations of the appliances. For example: chlorinated, sulphurous, ammonia or sodium products and diverse acid products
- All the requirements of the present regulation concerning ventilation and purifying shall be respected.

GUARANTEE LIMITS

Warranty is void if following instructions are not respected:

- The heaters are only designed for use in non-domestic applications with exclusion of any other utilization.
- Heaters must be installed inside the room, protected against humidity and bad weather conditions.
- Heaters must not be installed in atmospheres containing aggressive or corrosive vapors, even in small concentrations as the combination with combustion products can deteriorate the material (e.g. : chloride, sulphurous, ammonium, sodium and all kind of acid products)
- Storage of heater must be done carefully avoiding shocks and ensuring that heater is protected against bad weather conditions.
- The installation must be in accordance with these instructions

Modification to this appliance is not authorized

2 Technical specifications

	According to CE	Units	HYPERTUBE L21
Nominal heat input		kW Hi	21
Combustion efficiency	>85	% Hi	90
Radiation factor		-	0,57
Seasonal efficiency	>74%		>75%
NOx class	>1	-	4
Electrical connection		-	230/240V 50Hz
Fuse protection		-	1 fuse 5A
Starting electrical power		VA	115
Functioning electrical power		VA	80
Combustion air & venting		-	A2, B22
Combustion air inlet opening type A & B		mm	Ø35
Flue outlet diaphragm diameter		mm	Ø48
Air pressure switch adjustment		Pa	64
Turbine discharge		mm	Ø133
Weight		kg	65

Adjustments in function of gas

Distributed gas		2H, 2E	3P	3B/P
Country		NO/PL/SE	PL	NO/SE
Gas reference		G20	G31	G30/31
Heat input (Hi) of gas reference		34,02 MJ/m ³	46,34 MJ/kg	45,65 MJ/kg
Nom. Inlet pressure mbar		20	37	30
Min. inlet pressure min mbar		17	25	20
Max. inlet pressure max mbar		25	45	35
L21	Ø injector mmx100	390	240	240
	Pressure by injector mbar	11	BR*	BR*
	Gas flow 15°C 1013mbar	2,22 m ³ /h	1,63 kg/h	1,66 kg/h

* BR = blocked regulator (see page 20)

3 Dimensions

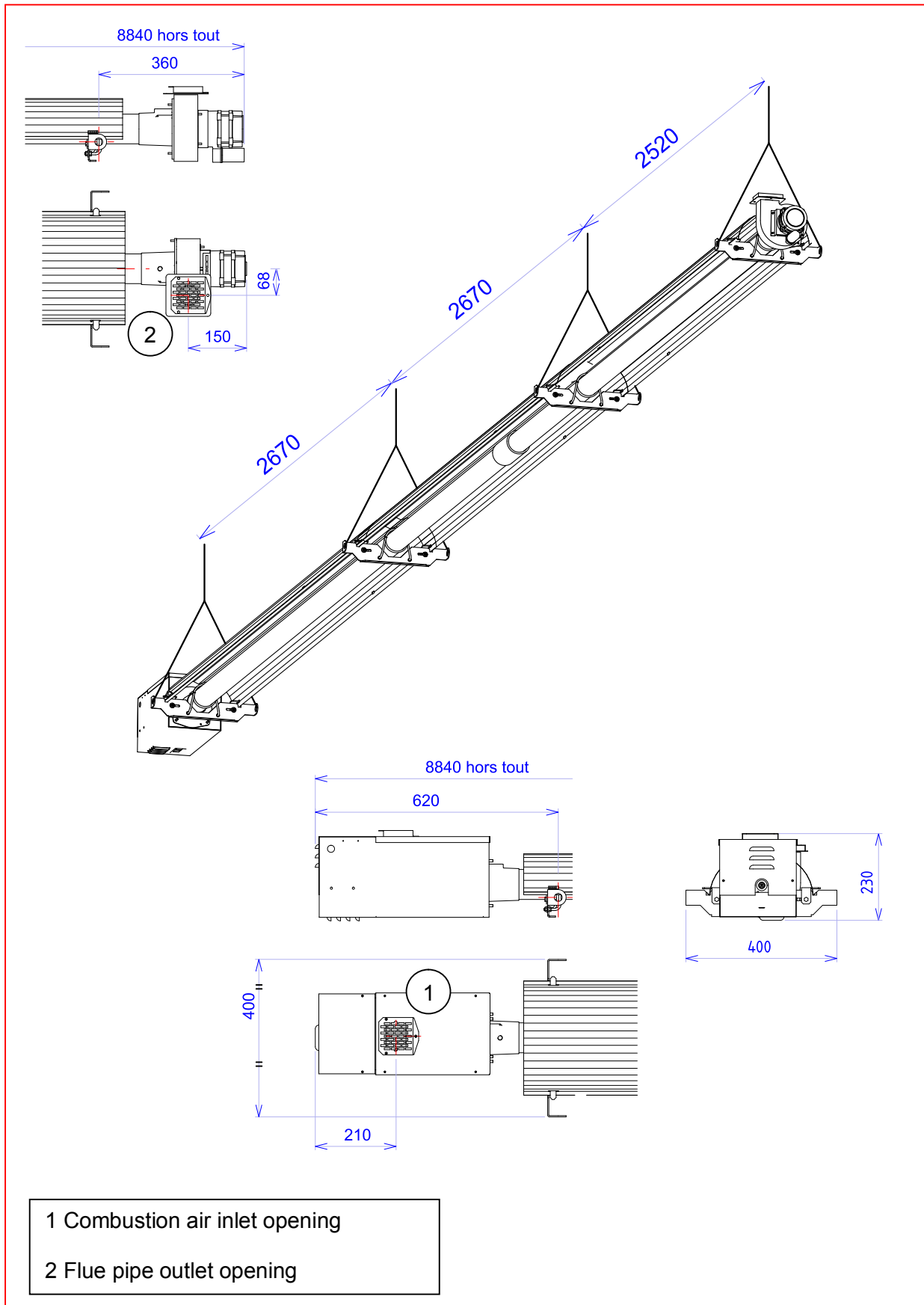

4 Appliance assembly

a/ Packaging

Quantity	Designation
1	Box containing burner / extractor
1	Tube Ø76,1 – lg : 4 400
1	Tube Ø76,1 – lg : 3 750
3	Reflector – lg : 2 824
2	Turbulator for tube Ø76.1 – lg : 1,00m
1	Turbulator for tube Ø76.1 – lg : 2,00m

b/ Tubes preparation

The short tube (B) is equipped with a turbulator length 2 meters on the extractor side and another turbulator of 1 meter (N) on the sleeve side.

The long tube (A) is equipped with only one turbulator of 1 meter (N) on the sleeve side.

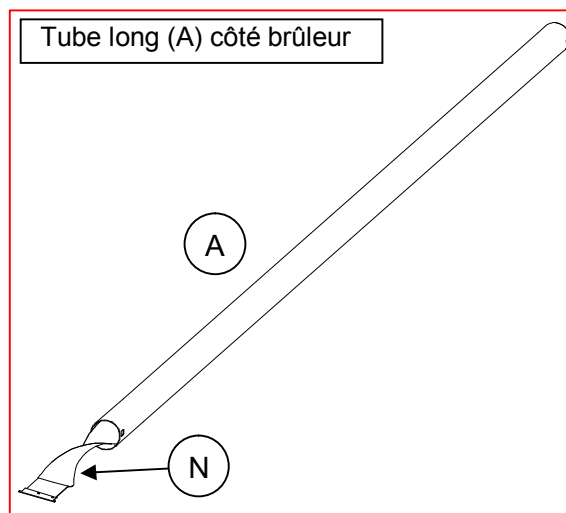
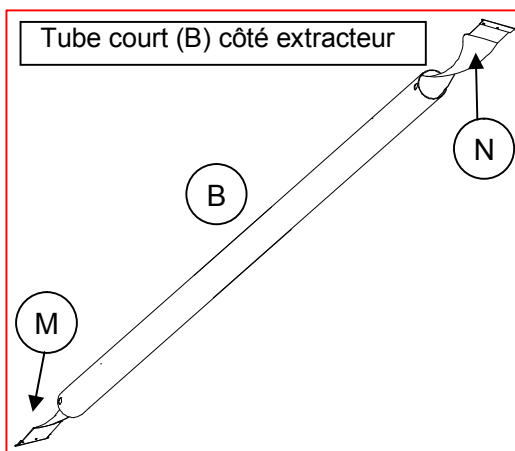

Detail of the position of the turbulator (M) inside the tube (B) on the extractor side.

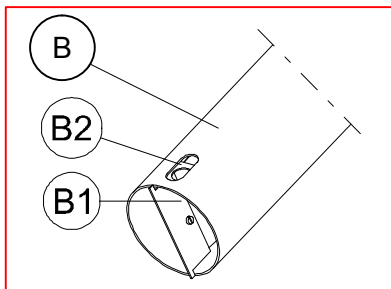
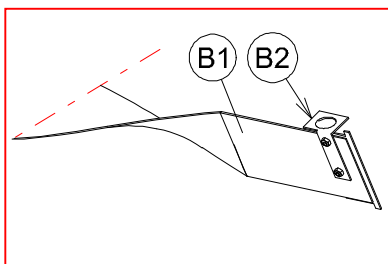

Mark	Designation
B	Short tube
B1	Turbulator
B2	Fixation part to be fixed only on the turbulator of length 2 meters, to be positioned in front of the oblong hole of the tube.

c/ Appliance assembly

Provide for hanging points under the roof following figure page 5.

The total incline should be between 0 and 100mm maximum, Burner should be lower than the Extractor.

The long tube (A) is mounted burner side (D), the short tube (B) extractor side (E). The central sleeve (F) is used for the connection of the 2 tubes.

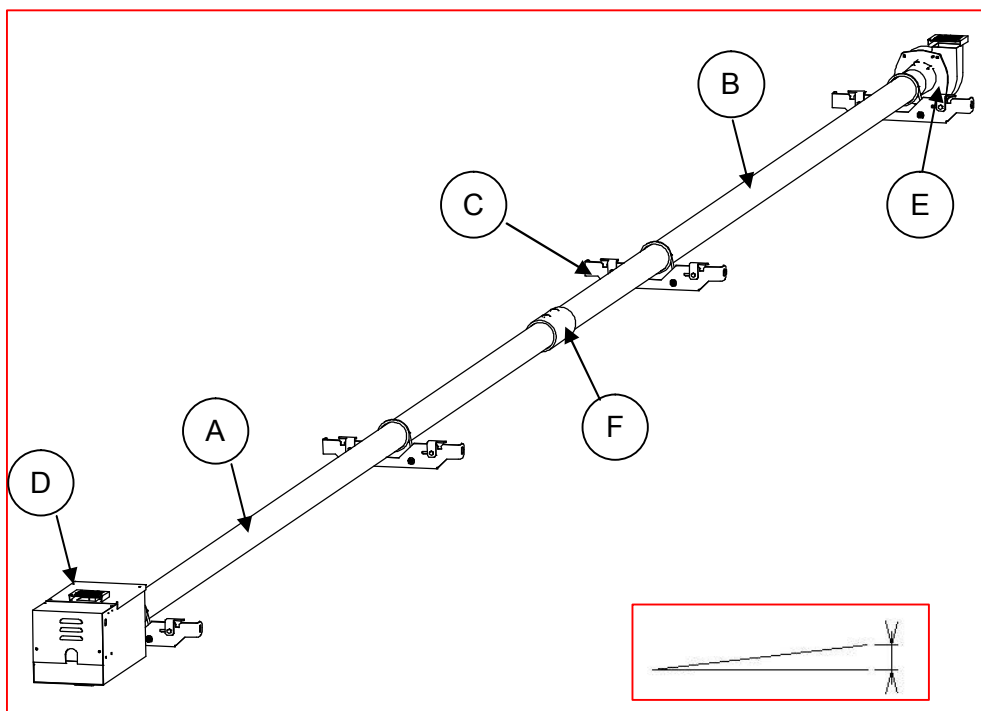

Tubes are fixed on brackets (C) with fixing rings.

Attention to respect the position of the brackets (C).

The hanging holes have to be always in the direction of the extractor (E).

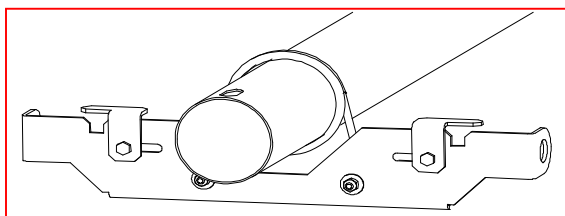

d/ Burner , sleeve and extractor assembly.

Make certain that the screw (A2) goes through the elongated hole (A1) ensuring so that the moving elements will come to a standstill!!!

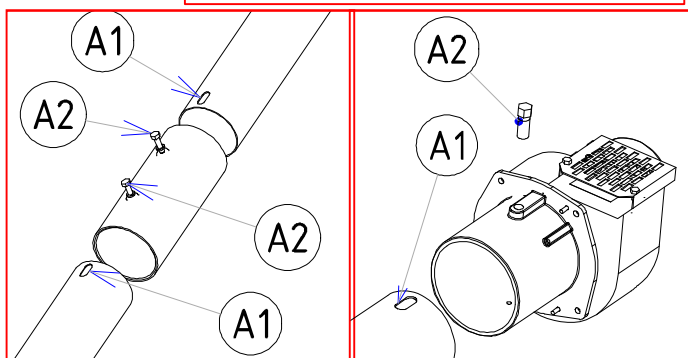
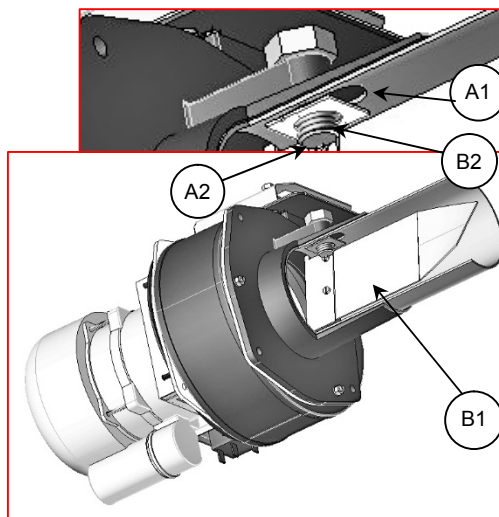
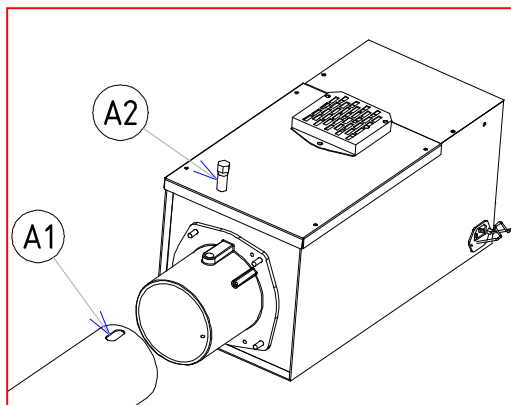

e/ Reflectors assembly

Attention: Take off the plastic protection of the reflectors (H).
All the 3 reflectors are similar.

Put the fixing brackets of the reflectors (G) in open position.

Position the reflector (H) in the grooves of the traverse.

Put the fixation parts of the reflectors (G) in closed position and screw these parts in order to maintain the reflectors.

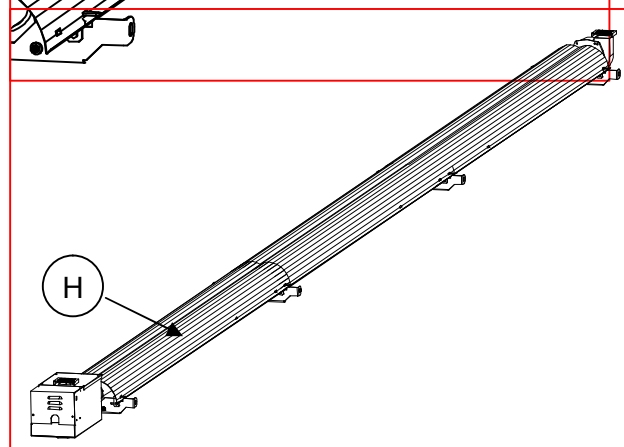
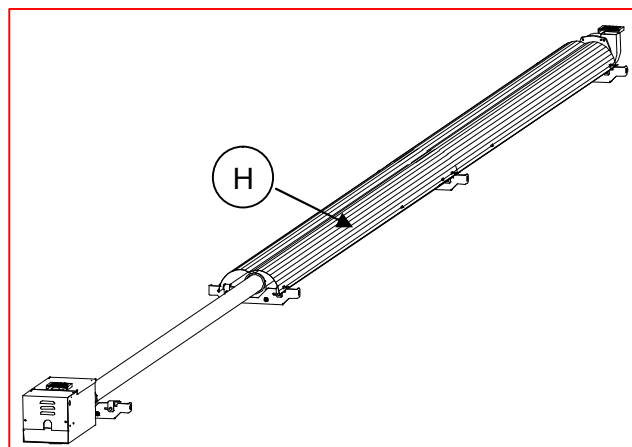
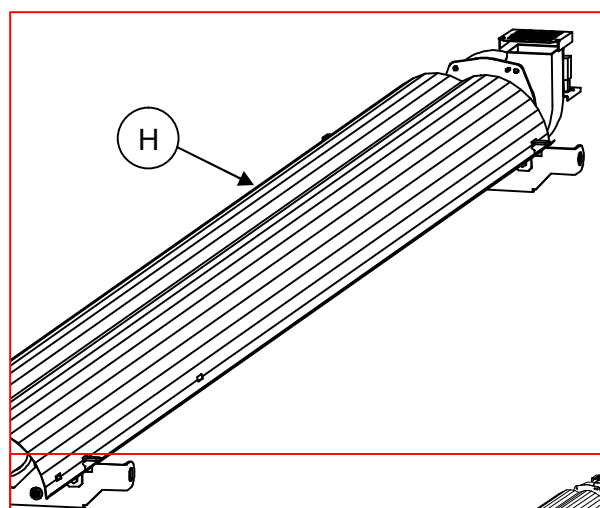
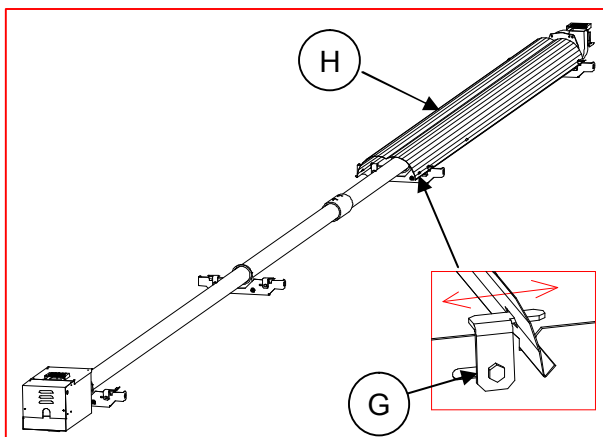

f/ Mounting of anti-rotation strap

Installation of the anti-rotation strap of burner unit.

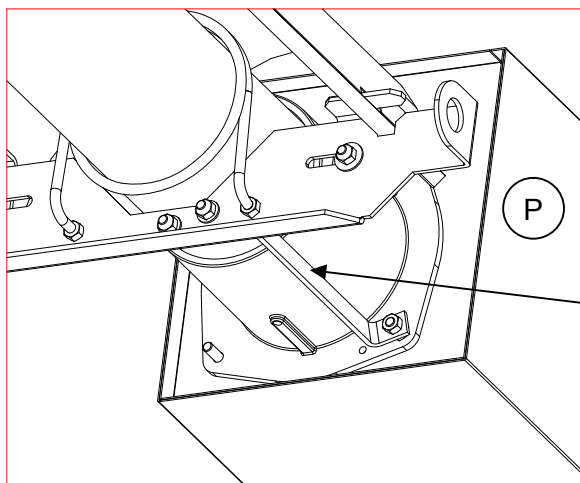

At burner unit side (P), attach the anti-rotation strap (S) to the screw surpassing the socket with the supplied lock nut (T).

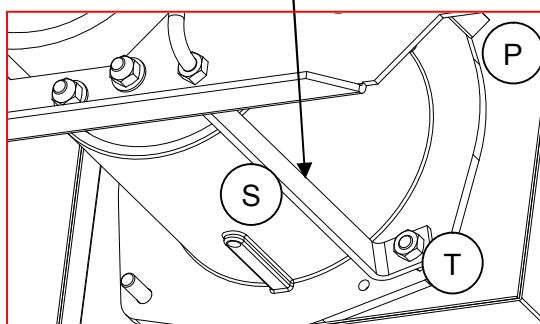

Crosswise (C), fix the anti-rotation strap (S) with the supplied 2 screws and nuts (U) applying the hereto provided 2 holes.

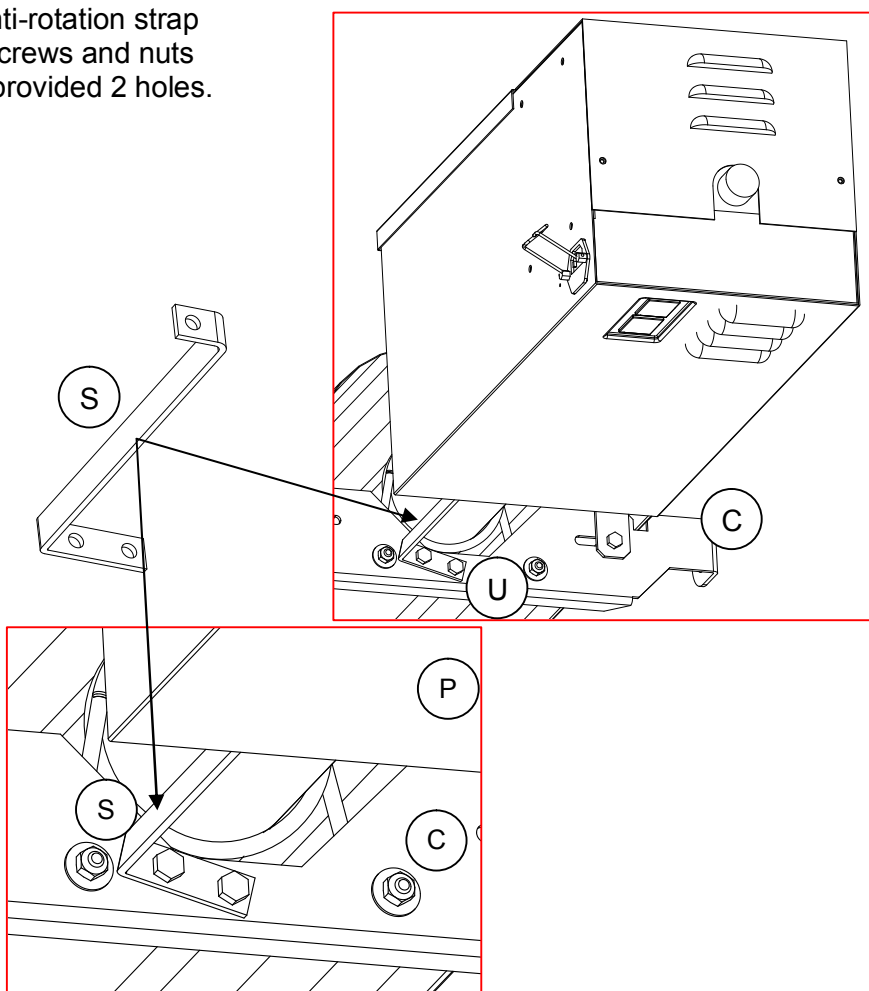

Bottom view, installed unit

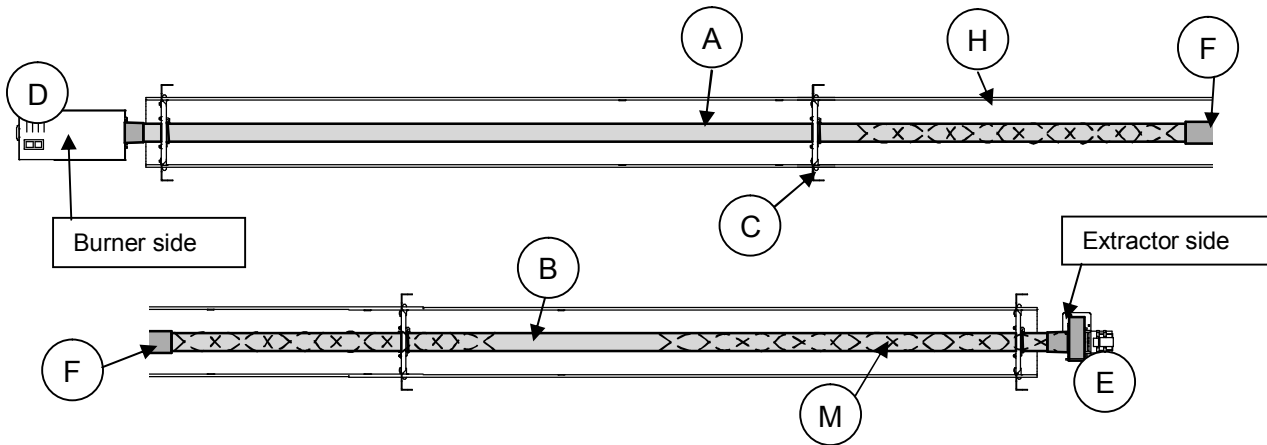

5-Suspension/Fixing

Suspend the radiant tubes by means of chains or cables of adequate length fixed to framework, under shores or portals, between pillars or against a wall. Optional fixing parts can be supplied.

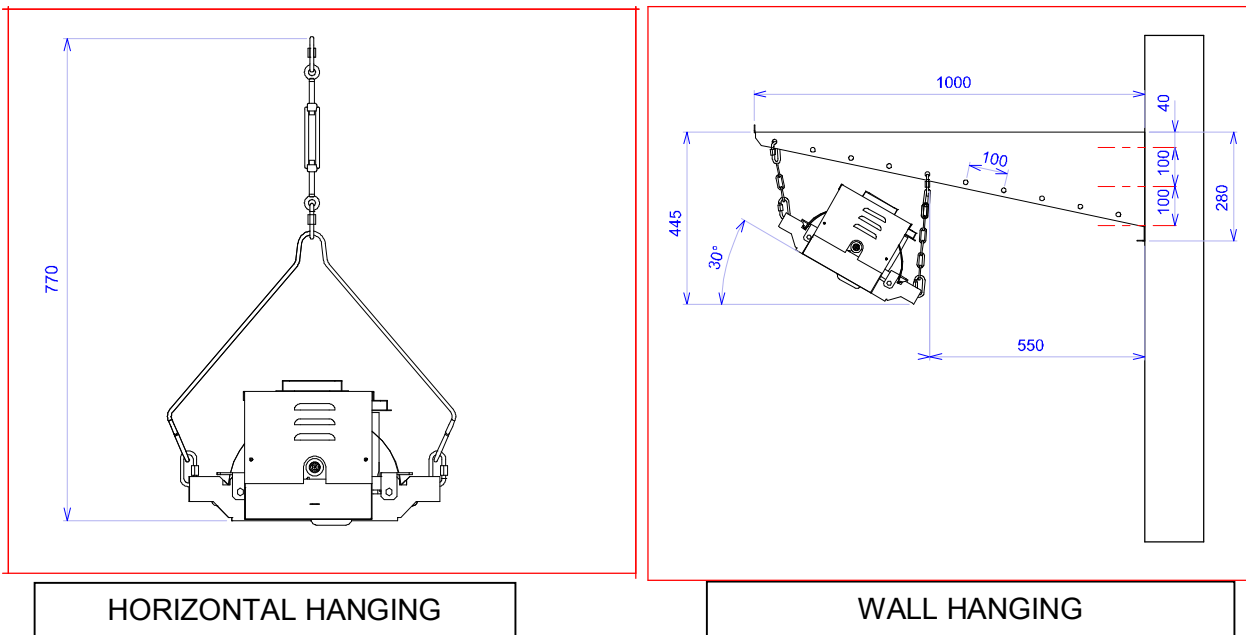

ATTENTION: For a good system efficiency, do not incline the unit up to 30°!!

Hanging type	Designation	Ref. SBM
Horizontal	KIT SUP HOR L21/U35	5720009
Wall	KIT SUP MUR L21	5720066

SAFETY INSTRUCTIONS

Care must be taken to install the anchor points perpendicular to the end supports.
The model **L21** contains 4 points of anchorage

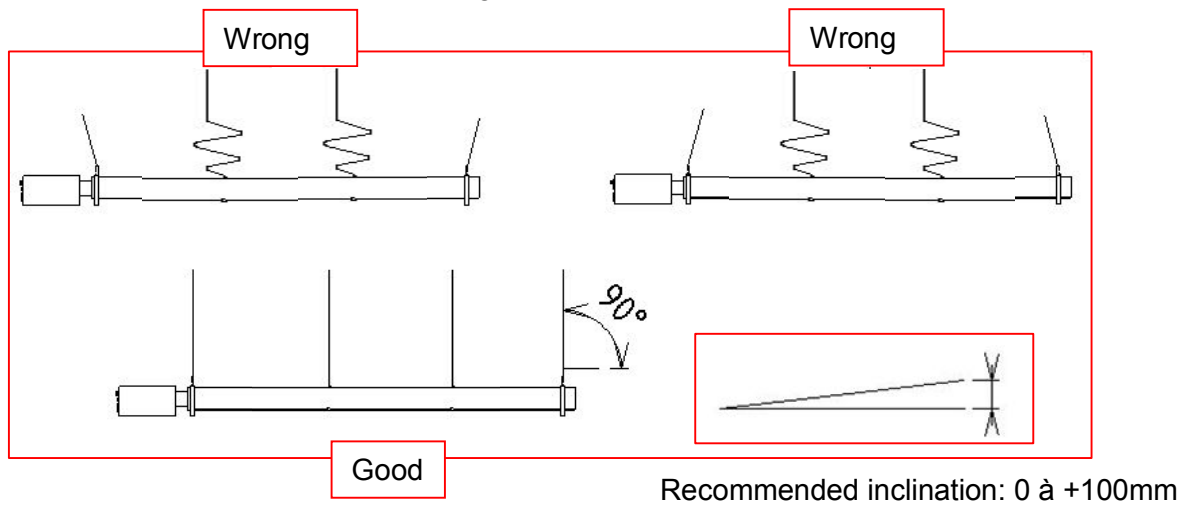

Very important:

Make use of a flexible suspension system enabling the expansion of the emitter tubes but avoiding extreme oscillations.

Wall supports, **supplied on request** take this instruction into account.

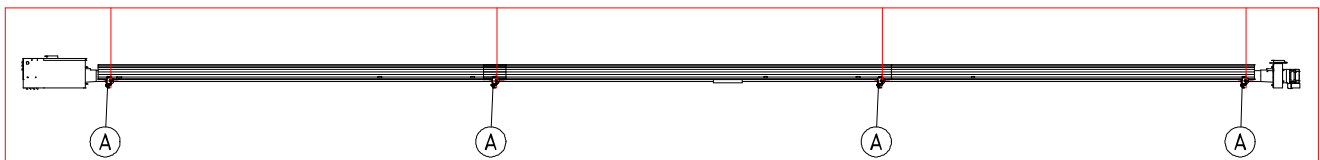

Mark	Designation
A	Required anchor points

6 Safety clearances

a/ Minimum distances towards unprotected combustible materials

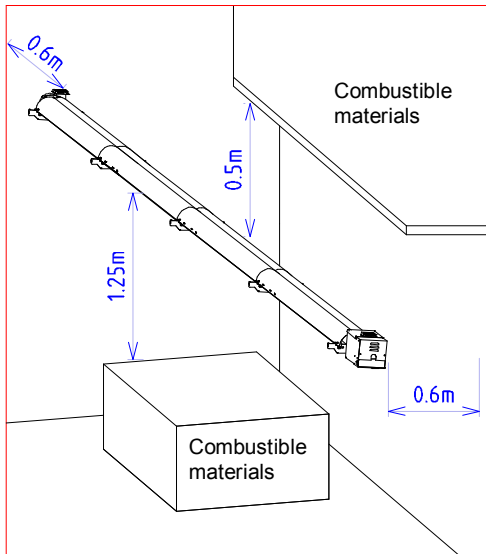

Units must be installed so that the minimum clearances towards unprotected combustible materials are maintained.

Furthermore, a thermal insulation is to be installed between the hanging support of the appliance and the material on which it is fixed, in case this material should be of a flammable nature.

ATTENTION: Refer to the rules in force.

b/ Recommended minimum height

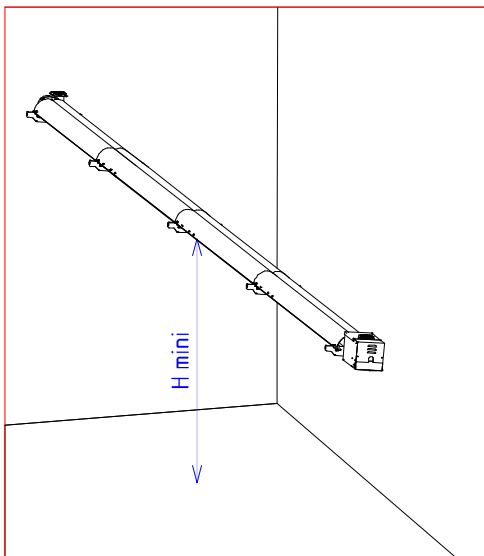

The minimal recommended mounting height in relation to the ground and in the case of global heating of a closed building is:

Appliance	Horizontal hanging	Wall hanging
L21	3,70 m	3,10m

Heights and mounting positions depend of the building structure and of the study implantation.

PARTICULAR CASES:

- 1) During the installation of an appliance above an overhead crane, provide if necessary the protection of the crab's motor and of electrical equipment by the means of an insulating sheet.
- 2) Avoid the installation of radiant tubes above bulky machines or stores which could prevent the diffusion of radiation towards the workers or users.
- 3) In the presence of lifting ramps (vehicle repair workshops) care should be taken not to fit the radiant tubes directly above these ramps. In fact, deterioration may occur to cars with bodies or covers which could stay on the high position of the ramp.
- 4) In the case of a workshop including pits or hidden zones, we cannot guarantee in these zones the same conditions of comfort as in the rest of premises.

7 Evacuation of combustion products

According to the type of building, to the insulation or to the air tightness of the building, there are 2 possible solutions:

Type A - Throwing out of the combustion products into the atmosphere

Type B - Individual fluting of each unit outside the building.

The following indications about the air renewal concern the good functioning of the appliances. Do not forget also to take into account the rules concerning people leaving in the heated premises.

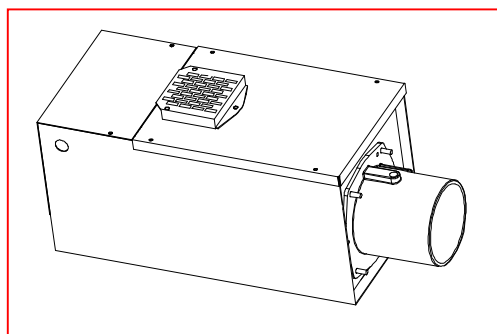

Burner side

TYPE A

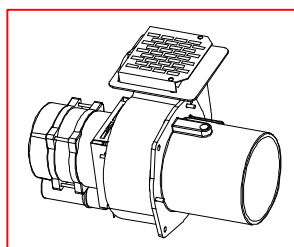

Extractor side

TYPE B

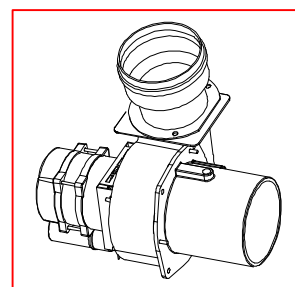

TYPE A

THROWING OUT OF THE COMBUSTION PRODUCTS INTO THE ATMOSPHERE

SBM radiant tubes have a good combustion hygiene which has been controlled for the CE mark. However, they can only be installed and used **in well ventilated premises**.

In industrial facilities, radiant tubes **HYPERTUBE L21** can be installed without evacuation ducts for the combustion products within the limits of the regulations in force. In that case, no modification has to be brought to the units which are already equipped with a protection grille.

Attention: In public buildings, the evacuation of flue gases is obligatory!

* However we draw your attention to the fact that combustion products emitted into the atmosphere can perceptibly modify the humidity level depending on the air change rate of the building.

In case where products of combustion are not evacuated outdoor, **ensure that the location where the unit is installed provides sufficient air to ensure a good functioning of the unit** and the dilution of the combustion products by **10 m³ /h per kW installed**.

Do not allow combustion products to come into contact with combustible materials.

WARNING: refer to the rules in force.

TYPE B

a / INDIVIDUAL FLUTING OF EACH UNIT OUTSIDE THE BUILDING

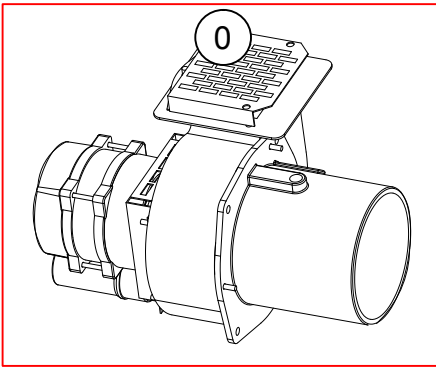

- Remove grill at exhaust pipe (0).
- And replace with connection piece Ø100 (1) for pipe **FLUE CONNECTION DN100** (Réf SBM : 5720014)
- Do not use grill as protection for a flue pipe end.
- Air inlets must be sufficient in the premises in order to allow a good supply of the burner with air of combustion

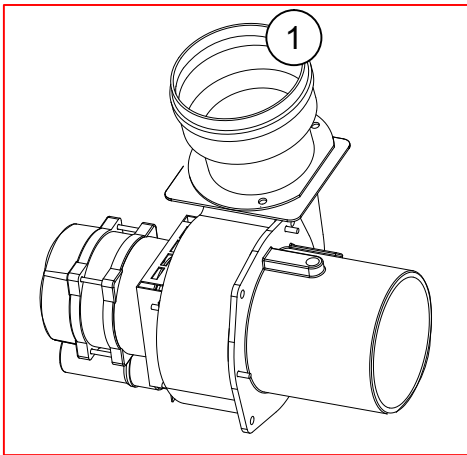

Plan for an external air flow of at least **1.75 m³/h per installed kW**.

SAFETY INSTRUCTIONS CONCERNING THE INDIVIDUAL EVACUATION DUCT:

- No reduction of diameter can be accepted after the connection piece.
- It must be made out of stainless steel or aluminum with **smooth** and **rigid** duct.
- The evacuation must be realized according to the norms in force in each concerned country.
- The **maximum** length of the exhaust pipe shall not be greater than **16 meters of straight length** (see on the spreadsheet hereunder).
- The duct must not include low point.
- Any accessory made out of plastic or PVC is absolutely prohibited.

	Air flow	Exhaust gases temperature	Exhaust gases volumic flow	Exhaust gases massic flow
L21	47 m ³ /h	175 °C	82 m ³ /h	61 kg/h

Singular pressure drop equivalent lengths:

Accessory	Equivalence straight length	Designation	Ref. SBM
Elbow 90°	2 meters	FLUE PIPE BEND 90° DN100	5720018
Elbow 45°	1 meter	FLUE PIPE BEND 45° DN100	5720019
Std protection cap against rain	2 meters	Not supplied	
1m rigid hose	1 meter	FLUE PIPE 1M DN100	5720017

WARNING: refer to the rules in force.

8 Installation and connections (Gas and electricity)

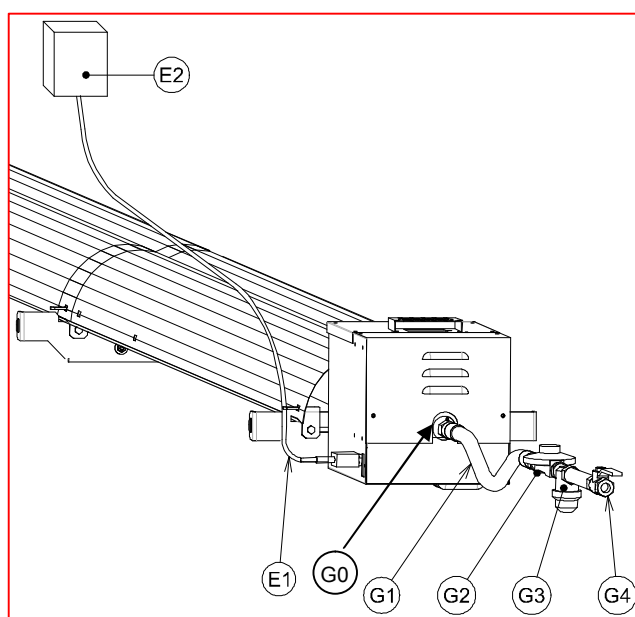
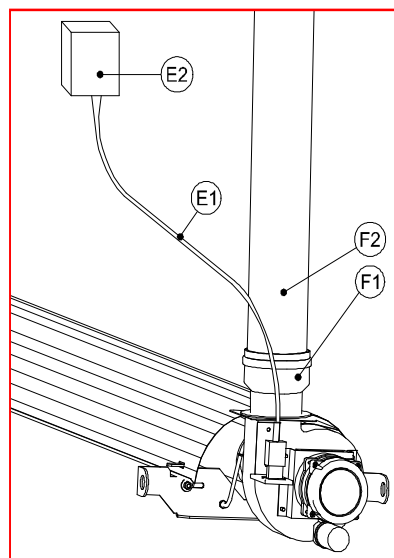
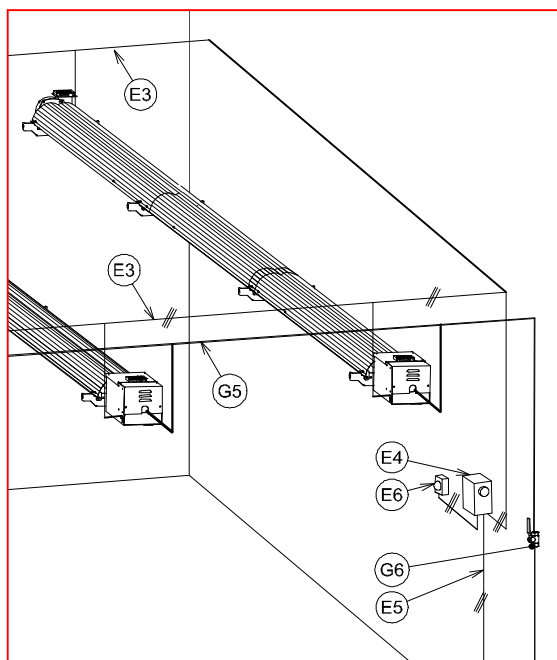

a/ Electrical connection

Mark	Designation
E1	Power cable (supplied with unit) L = 1,00m (3 x 0,75 mm ²)
E2	Junction box
E3	Power supply from the controller
E4	Controller (SBM accessory)
E5	Power supply 230V 50Hz phase neutral earth
E6	Space sensor (supplied with SBM controller)

In case of electrical installation without neutral (or bad quality of the neutral), plan an insulation transformer in order to create an artificial neutral (Ref. SBM : 5720032).

WARNING: In no case should the electrical cable be located on stay on the converter or on the functional block of the appliance.

b/ Flue system

F1	FLUE CONNECTION DN100 (Ref. SBM : 5720014) for type B connection
F2	FLUE PIPE 1M D100 (Réf. SBM : 5720017)

c/ Gas connection

G0	GAS FITTING G1/2m G3/4f (Ref. SBM : 9805079) pour G20, G30/31 and G31	
G1	METALLIC HOSE G1/2F 700mm (Ref. SBM : 9805013) for G20, G30/31 and G31	
G2	Gas regulator	VFD G20 E300 S20 3M3/H (Ref. SBM : 5730002) for G20
G3	Gas filter	VFD G31 E1.5B S37MB 4KG/H (Ref. SBM : 5730000) for G31
G4	Gas valve ¼ turn	
G5	Gas pipe	
G6	Main gas valve	

d/ " Failure signal transmission " Option

This option allows the transmission of the failure signal (on each individual unit or per group of units) to a control panel or the BMS system. To ensure safe working, the transmission of the failure signal happens by means of a dry contact controlled by a relay incorporated inside the unit (3).

In order to avoid undesirable shutdown at each ignition attempt, it is recommended to delay the failure signal of the control panel or BMS by 30 seconds.

The unit is delivered in standard version with a closed contact, if you want open one, you may ask us at the order.

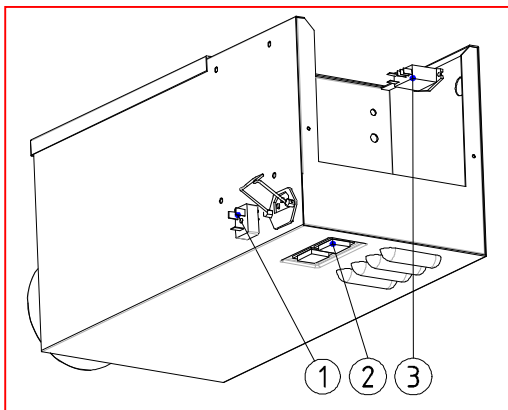

- (1) Lockout relay plug
- (2) Red light default
- (3) Lockout relay
- (4) Dry contact

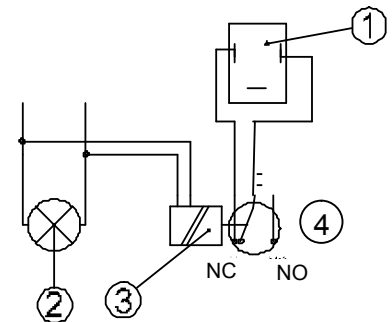

9 Temperature regulation

SBM recommends the regulation of radiant tubes with a control module type **VisioLon Ind-I** (3 temperatures thermostat + clock) or **EasyLon** (simple thermostat).

Each control module **VisioLon Ind-I** can drive **2 zones** of **7 radiant tubes each**. For a bigger quantity, provide a relay per zone, whose coil is powered by the VisioLon outputs (zone A : S1 and N terminals, zone B : NO and N terminals).

Each **EasyLon** controller can manage **1 zone** of **7 tubes**. For a bigger quantity, provide a relay per zone, whose coil is powered by the EasyLon outputs (14 and 18 terminals).

SBM can provide a **KIT COFFRET CONTROLE 2 ZONES** (ref : 9704014), including:

- A waterproof box IP65 12 modules
- A residential current device 16A - 30mA

This kit allows the installation of the controller to manage up to **7 tubes** per zone.

SBM can provide a **KIT COFFRET CONTR.REL. 2 ZONES** (ref : 9704015), including:

- A waterproof box IP65 12 modules
- A residential current device 16A - 30mA
- 2 relays 230VAC 10A

This kit allows the installation of the controller to manage up to **18 tubes** per zone.

We advise to respect the instructions concerning the material and particularly:

- To position the sensor at about 1.5m from the ground between two appliances so that it receives a homogeneous radiation,
- To insulate the sensor from the wall on which it can be found in order to avoid the cold radiation of the wall through the interposition of an insulating material (glass wool, wood, etc.),
- The connection between sensor and regulator must be made out of armored cable or phone cable, 2 pairs.
- In any case, do not put these wires in the cable path which already contains many wires carrying energy.

Designation	Ref SBM
ROLL SENSOR CABLE 20M/66FT	8791000
ROLL SENSOR CABLE 60M/197FT	8791001
ROLL SENSOR CABLE 300M/984FT	8791002

10 Programming

The **VISIOLON Ind-I** shall be set so as to activate the start up about 30 minutes before the premises are occupied. The time lapse should be modified according to the inertia of the building and to the external temperature.

In the case of a very low external temperature, it is advised not to stop the heating during periods of inoccupation, but instead to simply reduce the temperature.

It is advised not to stop the heating during short interruptions in the use of premises.

11 Setting up

- After resistance test for mechanical seals and cleaning of gas line:
- Clean the gas network.
- Check that electrical supply is correct.
- Check presence and correct state of the flue installation.

FUNCTIONNING CYCLE:

Appliances are regulated in factory and do not need any additional adjustment on site.

- As soon as the electrical supply is turned on, beginning of the pre-purge sequence of about 15 seconds (yellow control lamps light).
- Control of the negative pressure in the tube through differential pressure switch.
- When the negative pressure is sufficient, the ignition spark starts and the electromagnetic gas valve opens.
- When the sensor detects the flame, the ignition spark stops and the appliance functions as long as it is supplied in gas and in electricity.
- . If for whatever reason the flame is no longer detected, the electro valve closes and the unit goes to lockout.
- Then the appliance attempts another ignition and a second working cycle starts.
- After 3 attempts of ignition, the unit goes to lockout.
- In the event of the 3 ignition attempts without success, the unit again goes to lockout. The ignition sequence can only start again if the electric supply is cut and reconnected some seconds later.
- . While operating, only the yellow control light stays on.
- In case of technical problem, refer to paragraph 14 « Faults - possible causes ».

12 Maintenance

We recommend checking the appliance and the installation at least every year.
The checking must be made by skilled personal. A maintenance contract is advised.

ATTENTION: refer to the rules in force.

**WARNING: INSULATE GAS AND ELECTRICITY BEFORE ANY MAINTENANCE WORKS.
Check that access conditions and minimum distances are respected.**

List of necessary tools:

Brush, duster, paint brush, flue brush, vacuum cleaner, small case of electromechanical tools.

MAINTENANCE INSTRUCTIONS:

1) Emitter tubes

Clean up the external tubes with a metallic brush – remove the burner block to inspect the inner side. In case of a considerable dust deposit the tubes should be cleaned inside. Use hereto a bottlebrush with appropriate diameter or a dust aspirator.

2) Reflector:

Inspect inner side of reflector and if necessary clean with soft cloth and soap water. If necessary use soft metal wax.

3) Extraction Turbine

Check that it turns freely and remove with a brush any accumulation of deposits that may exist on blades. Also remove dust from the fan volute.

4) Motor and cooling fan of motor axis:

Remove dust with compressed air (careful with the turbine over speed) and clean the aeration ears.

5) Ignition and security box:

Remove the electrical plate and remove dust if necessary. Check that the control contact of negative pressure occurs correctly.

6) Gas tray set and mono-electrode

- Disconnect the electric wires of the electro valve.
- Take out the gas tray set by taking out the assembly screws on the face.
- Clean the injector, the burner and the burner head which must not be sooted up.
- Clean the electro valve and regulator filters and the cartridge filter.
- Remove the electrode mounting panel. Disconnect the electric wires, inspect the electrode brush it and change it if necessary. Control the gap which must be 4 mm.

7) Connection of pressure switch:

N°	Designation
1	Burner depression plug (green pipe)
2	Pressure plug on the air inlet

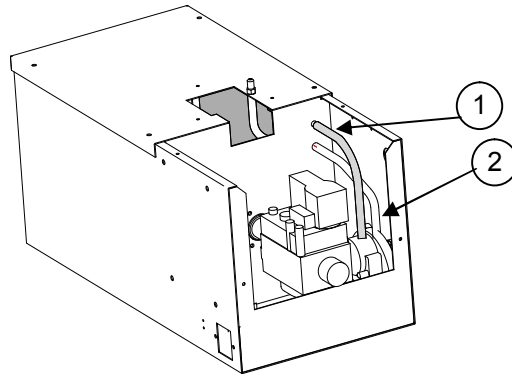

8) Evacuation duct:

Check and clean the fume ducts according to the rules in force.

REPLACEMENT OF PARTS:

Mono-electrode:

Dismantle the electrode carrier by unscrewing fixation screws. Change the set if necessary. The gap between the electrode and the earth electrode must be 4 mm.

Burner and injector:

Dismantle the electrode carrier. Unscrew the burner, unscrew the injector and change them if necessary. When the injector is dismantled, the joint must be replaced.

Ignition and security box

To take it out, take off the 4 fixation clips retaining it to the frontage panel, disconnect the connector and disconnect the HT ignition wire.

Pressure switch

Open the superior bonnet, disconnect and identify the cable terminals and take out the pressure switch from its support.

Fan Motor Group

Loosen the 4 nuts to easily remove the fan motor group. To unfix the turbines, loosen the six-sided nut by means of an Allen key on the flat surface of the motor axle.

13 Gas change

- The gas conversion must be done by qualified technicians.
- The injector (5) is the only part to remove in order to convert to another gas
- We refer to the table at page 4 showing the injector diameters to be respected.
- This table also indicates the inlet pressure and the pressure by injector that must be respected.

NOTE : A conversion kit is available on demand (consult our price list for components). The kit comprises: injector, seal and gas label (must be adhered on the old label).

Gas-Pressure	Injector	Designation	Ref SBM
G20-20	390	KIT I G20-20 U21/L21/U25+/L21+	5820028
G31-37	240	KIT I G31-37 U21/L21/L21+	5820065
G30/31-30	240	KIT I G30/31-30 U21/L21/L21+	5820071

Successive checks to be done :

- Check inlet pressure of working unit by means of a manometer connected to the pressure connection (B) (See also table at page 4).
- Check the injector pressure at gas pressure connection (D).
- Adjust pressure at the injector by using the adjustment screw. (C) (See table on page 4).
- Stick the appropriate gas label

NOTE: For the 3rd family gases 3+ PROPANE or BUTANE the regulator is blocked (3) (completely screwed in).

Mark	Designation
1	Gas valve inlet
2	Supply pressure intake (unblocked the screw in order to measure the pressure)
3	Pressure regulator (remove the brass plug terminal in order to access to the regulator screw)
4	Injector pressure intake (unblocked the screw in order to measure the pressure)
5	Brass injector (carved in mmx100)
6	Electric plug of the valve

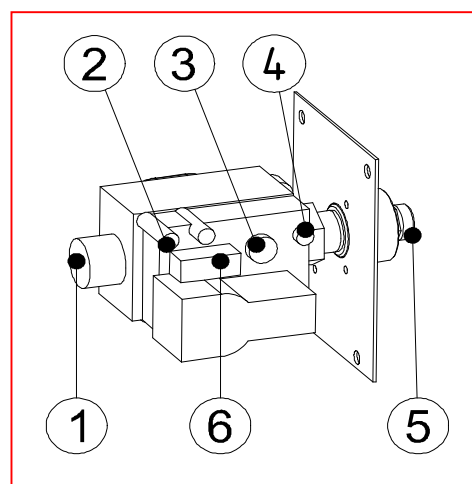

14 Faults – Possible causes - Solutions

Before any replacement of components internal to the appliances, be sure that :

- 1) The electrical supply of appliances is correct.
- 2) The gas is correctly supplied until the gas inlet of one or several appliances. (gas filter cleaned).

FAULTS	POSSIBLE CAUSES	SOLUTIONS
The motor does not run	Impeller jammed Motor seized up or failed burnt fuse	Clean the fan casing Unseized and/or change change the fuse
The motor turns but the appliance does not ignite	Clogged chimney Faulty motor Folded or disconnected pressure switch pipes Faulty ignition box Dirty impeller	Check - Clear To be cleaned or changed Replace them correctly To be changed To be cleaned (compressed air)
The pressure switch works correctly but there are no sparks	Cracked electrode Too big gap for ignition electrode Faulty control box	To be changed To be adjusted (3 mm ± 1 mm) To be changed
Sparks occur but the burner ignition does not occur.	Faulty electro valve Ignition and security box Electrode out of position Default of gas supply	To be changed To be changed To be repositioned Clean filter and pipes
Ignition occurs but the appliance stops afterwards	Faulty flame control Faulty ignition box	Check the ionization sensor and electrical connections To be changed
Abnormal noise. Ignition problems	Disordered burner. Friction of turbines Motor bearing defect Coupling of emitter tubes	Check regulating. to be adjusted Change motor Correct and verify

15 Electrical diagram

INTERNAL

N°	Designation
1	Electric supply+Fuse
2	Red lamp « Defect »
3	Yellow lamp « Operating »
4	Electro valve
5	Pressure Switch
6	Safety and ignition box

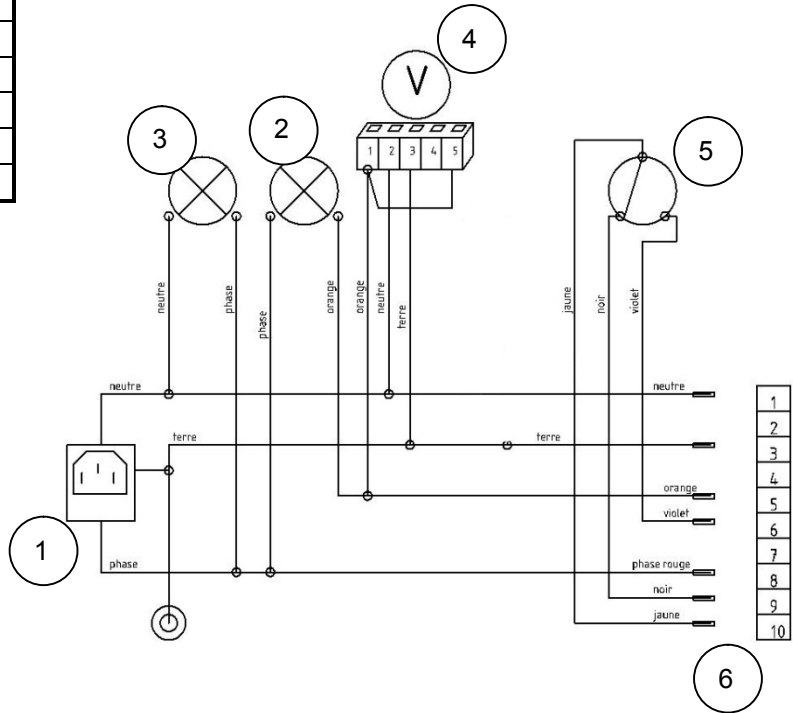

INTERNAL

With Insulation Transformer

N°	Designation
1	Electric supply+Fuse
2	Red lamp « Defect »
3	Yellow lamp « Operating »
4	Electro valve
5	Pressure Switch
6	Red lamp « Defect »
7	Insulation transformer

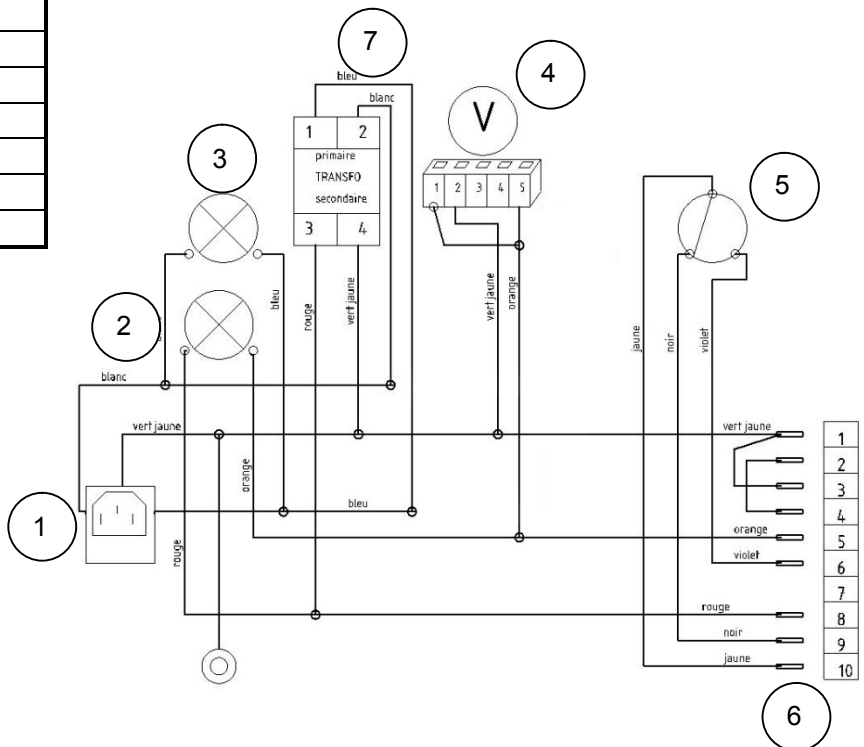

16 Options on request

Designation	Réf. SBM
PROTECTIVE GRILLE L21	5720046
REPORT DEF. HYPERTUBE (NC contact) Specify while ordering if NO contact	5720031
INDIVIDUAL INSUL. TRANSFO. U/L	5720032

17 Spare parts

L21

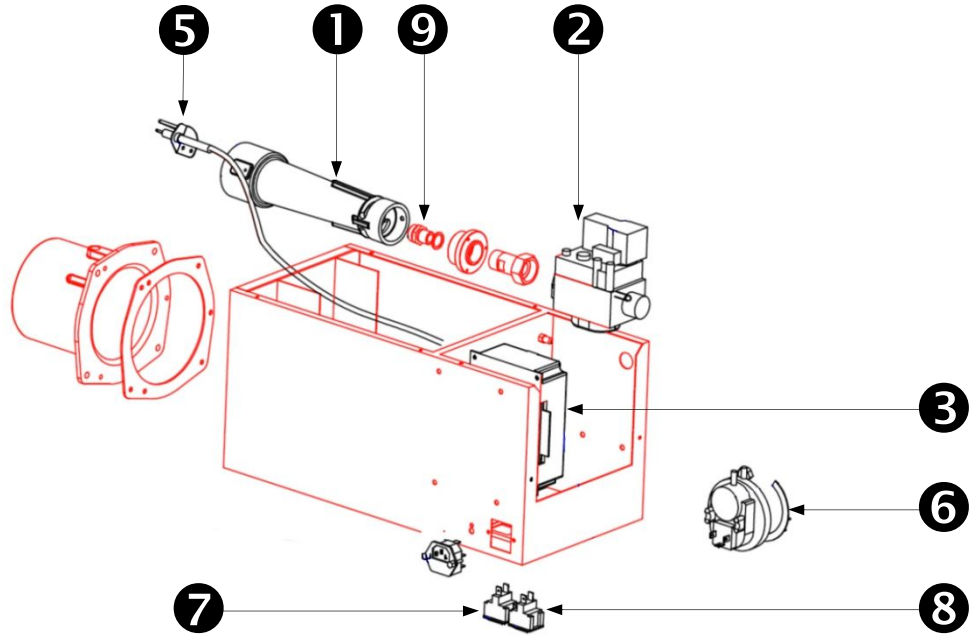

<p>1</p> <p>VENTURI BURNER F9</p>  <p>5820000</p>	<p>2</p> <p>SOLENOID VALVE U/L/L+</p>  <p>5820026</p>	<p>3</p> <p>CONTROL BOX PACTROL</p>  <p>5820016</p>
---	---	---

<p>4</p> <p>EXTRACTOR L21/L21+</p>  <p>5820041</p>	<p>5</p> <p>IGNITER+CABLE HYPERTUBE</p>  <p>5820027</p>	<p>6</p> <p>PRESSURE SWITCH L21/L21+</p>  <p>5820048</p>
--	---	--

<p>7</p> <p>YELLOW LIGHT HYPERTUBES</p>  <p>5820053</p>	<p>8</p> <p>RED LIGHT HYPERTUBES</p>  <p>5820054</p>	<p>9</p> <p>KIT I</p>  <p>G20-20 : 5820028 (Injector 390/100) G31-37 : 5820065 (Injector 240/100) G30/31-30 : 5820071 (Injector 240/100)</p>
---	--	--